



Annex

7.0

Kühner AG, Dinkelbergstrasse 1, CH-4127 Birsfelden, Switzerland
 Tel: +41 61 319 93 93, www.kuhner.com, office@kuhner.com

A.1	Pressure Measuring System	2
A.1.1	Check of Pressure Measuring System	2
A.1.2	Adjust offset of A/D-channels.....	2
A.1.3	Adjust gain of A/D-channels.....	3
A.1.4	Test of A/D-channels	3
A.2	Test of input / output port	4
A.3	Analog output (recorder)	5
A.3.1	Adjust	5
A.3.2	Readout.....	5
A.4	Trouble shooting.....	6
A.5	Technical data	7
A.5.1	Technical data of 20-l-sphere	7
A.5.2	Technical data of KSEP 310	7
A.5.3	Technical data of KSEP 332	8
A.6	Spare parts	9
A.6.1	20-l-sphere	9
A.6.2	Parts / Diagram of KSEP 310	11
A.6.3	Spare Parts SP8xxx (number „xxx“ on drawings).....	12
A.7	Report - Mask.....	13



Please read this note !



This information is helpful !



Question and answer ! What is to do, when ...

A.1 Pressure Measuring System

A.1.1 Check of Pressure Measuring System

This test program displays the actual pressure reading of both channels. The maximum and minimum values are displayed separately. Please note that piezoelectric sensor's only allow measurement of "quasi-static" pressures or pressure changes. The preferred test method is to vent a given over pressure down to atmospheric pressure. Proceed as follows:

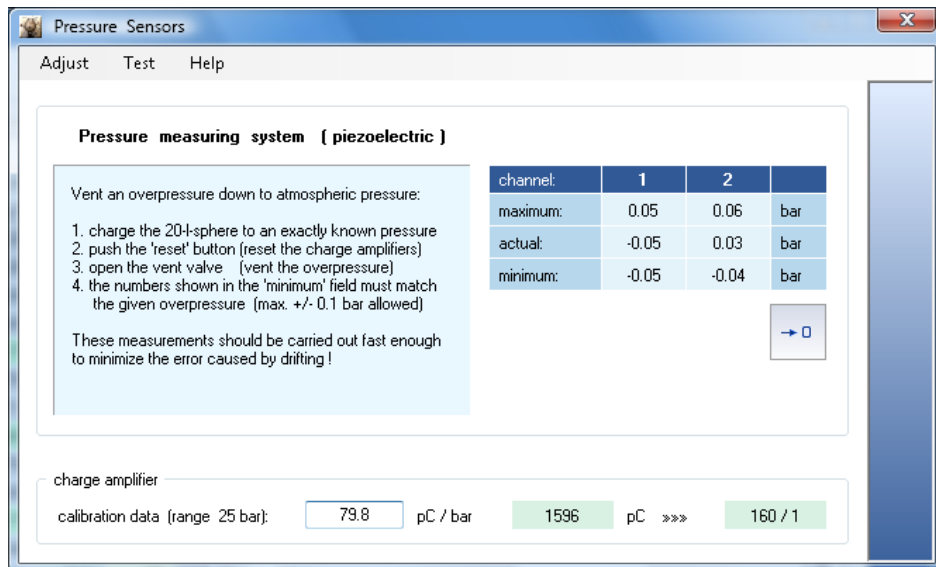

1. Charge the 20-I-sphere to an exactly known pressure.
2. Reset the display of "maximum, minimum" and the charge amplifier reading.
3. Compare the pressure deviations between the two channels when discharging the vessel (max. +/- 0.1 bar are allowed).



These measurements should be carried out fast enough to minimize the error caused by drifting. This test is not a calibration but a function check. Ageing effects of the sensor's are negligible. As long as both channels show matching results, they are assumed to be OK.

A.1.2 Adjust offset of A/D-channels

This tool helps to compensate for the unavoidable offset error of the measuring channels. For this purpose, the charge amplifiers and the pressure sensor's have to be connected. Correction is done by subtracting the stored offset voltage from the pressure signal.



This adjustment has already been done at the factory and must only be repeated when replacing the A/D-converter chip.

A.1.3 Adjust gain of A/D-channels

1. Adjust first the offset as described above.
2. Disconnect the 5-pole cable to the charge amplifiers (on printed circuit board).
3. Connect the A/D converter reference voltage to the measuring input.
4. Adjust screen readout to 20.0 bar using the variable resistor.



This adjustment has already been done at the factory and must only be repeated when replacing the A/D-converter chip.

A.1.4 Test of A/D-channels

The input to be tested must be connected to the line recorder output by means of a reference capacitor of 220 pF (to be ordered separately). An electrical charge proportional to the linear rising output voltage will be generated across the capacitor. This simulates a linear rising pressure signal. Set the charge amplifier range to 2200 pC (220 - 1) and start the test (enter key). The following values will be checked:

1. deviation of gain [%]	2.0
2. output of D/A [mv]	3972.5
3. input of A/D [bar]	5.12
4. stepwidth, actual	0.01
5. stepwidth, maximum	0.01
6. drift [bar/min]	0.00
7. missing codes	-----

passed



- Deviation of gain:
check eventually the gain settings.
- Maximum step width:
each step corresponds to 0.01 bar. Non-linearity increase this step width.
- Maximum drift:
during the test time of approx. 4 min., the charge amplifier is only allowed to have a certain drift. Clean all contacts and repeat the test.
- Missing codes:
no missed positions must be displayed



This test is very sensitive regarding insulation resistance and electrical interferences. In certain circumstances, the test has to be repeated. Only a capacitor with a very high insulation resistance is suitable (e.g. a Styroflex capacitor).

A.2 Test of input / output port

This tool gives you direct access to the power outputs of the KSEP 332. These outputs can be switched on and off independently.

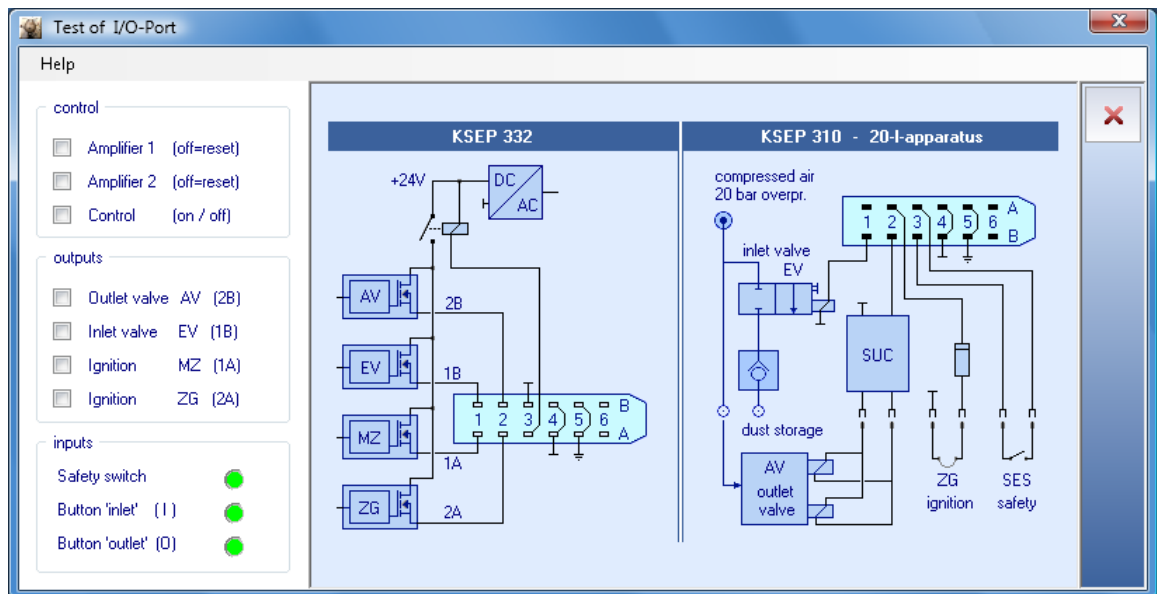

A.3 Analog output (recorder)

The transducer output is digitized at high resolution and stored in the KSEP 332 memory (0.2ms / 10,000 measurements per channel). The Personal Computer only receives part of it (500 measurements / channel). For test purposes the complete record of the KSEP 332 can be readout.

A.3.1 Adjust

Factor: this value sets the replay slow-down factor.

Span: outputs calibration voltages to the line recorder in the range of 0...5.25V corresponding to a pressure of -1 ... +20 bar at a resolution of 0.01 bar

Pen: Remote control for pen-lift and paper feed (on/off)

A.3.2 Readout

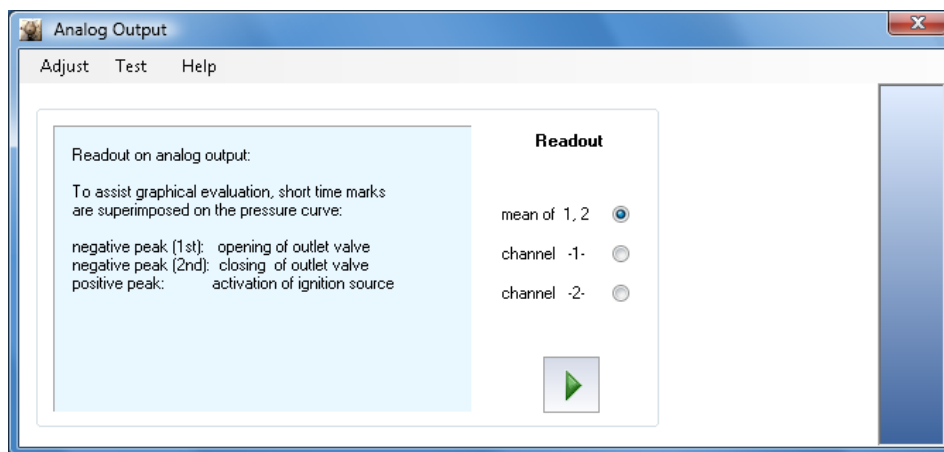

Each channel or the arithmetic mean value of both channels may be reproduced separately. To assist graphical evaluation, short time marks are superimposed on the pressure curve:

1. negative peak: opening of the outlet valve
2. negative peak: closing of the outlet valve
- positive peak: activation of the ignition source

A.4 Trouble shooting



Pressure at the moment of ignition: not 1 bar (absolute) !

- Adjust dispersion pressure to exactly 20 bar overpressure.
- Gauge on storage chamber may be defective.
- Clean the outlet valve.



Storage chamber does not hold dispersion pressure !

- Clean outlet valve; replace O-ring if necessary.



Part of the dust remains in the storage chamber !

- Adjust compressed air to exactly 20 bar overpressure.
- Clean the outlet valve.
- Dispersion system may be plugged, clean out.



Igniters not activated during normal test sequence !

- Foul contacts, clean ignition rods.
- No pressure rise in sphere



Explosion prior to correct moment of ignition !

- The dust may have caused strong electrostatic discharge.
- Insulate ignition leads.
- Clean or wrap chemical igniters.



Differences between both pressure measuring channels !

- Renew protection layer on pressure sensor's (silicone).
- Check adjustment of charge amplifiers.
- Re calibrate pressure sensor's.

A.5 Technical data

A.5.1 Technical data of 20-l-sphere

- Material of construction No.: 1.4435
- Wall thickness of inner jacket: min. 4 mm
- Wall thickness of outer jacket: min. 2 mm
- Volume of sphere: 20 l
- Volume of water jacket: 1.5 l
- Design pressure of sphere: 30 bar
- Design pressure of jacket: 10 bar
- Test pressure of sphere: 39 bar
- Test pressure of jacket: 14.3 bar
- Design temperature: 60 °C
- Bayonet ring aperture: 96 mm diameter
- Cleaning aperture: 140 mm diameter
- Sight glass: 30 mm diameter
- Measuring flange: 3 tapped bores M14 x 1.25
- Venting connection: hose ID. 12 mm
- Vacuum connection: Serto, 1/4" G
- Water connections: hose ID. 10 mm
- Overall dimensions (w,h,d): 650 x 875 x 820 mm
- Weight: 75 kg

A.5.2 Technical data of KSEP 310

- Compr. air connection on back: fitting: serto 1/4" G
nominal pressure: 20 bar
max. pressure: 30 bar
- Vacuum connection on back: fitting: serto 1/4" G
- Overall dimensions (w,h,d): 510 x 215 x 370 mm
- Weight: 13 kg

A.5.3 Technical data of KSEP 332

Control outputs (for KSEP 310 and ignition system)

Two 12-pole connectors according to DIN 41622 connected in parallel. The contacts are as follows:

- 5A, 5B: safety ground
- 4A, 4B: common and potential isolated ground return of 1A, 1B, 2A, 2B
- 3A,..3B: Safety switch (3A = plus / 3B = minus)
- 2B: Outlet valve 24V / 4A (current limited)
- 2A: Chemical igniters 24V / 4A (current limited)
- 1B: Inlet valve 24V / 0.6A (current limited)
- 1A: MIE system 24V / 0.6A (current limited)

Measuring unit

- Pressure range: +/- 20 bar
- Pressure resolution: 10 mbar
- Sampling time: 0.2 ms
- Recording time: 2.0 s
- Pressure transducer (2): Kistler Type 701A
- Charge amplifiers (2): Kistler Type 5041B
- Recorder output: 5.25V = +20 bar / 0V = -1 bar

Computer

- CMOS-Microprocessor: HD64180
- Program storage: EPROM 32 Kbytes
- Data storage: static CMOS RAM 32 Kbytes
- Data protection: Lithium Battery for CMOS RAM
- Interface: RS 232: 4800, N, 8, 2
- Mains supply: 230/115V, 50/60 Hz, 110W

A.6 Spare parts

A.6.1 20-I-sphere

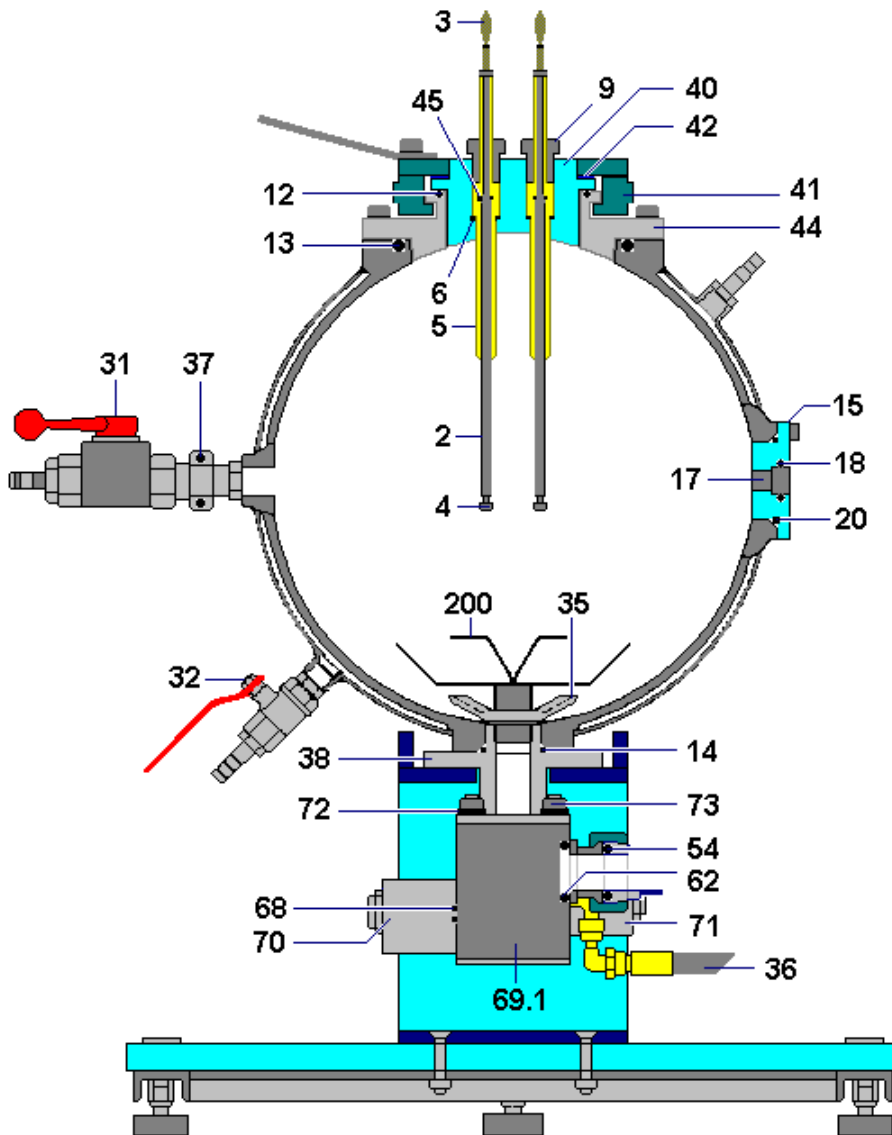

Dust storage container

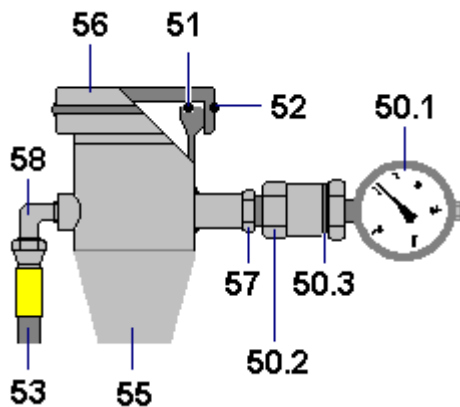

Vacuum

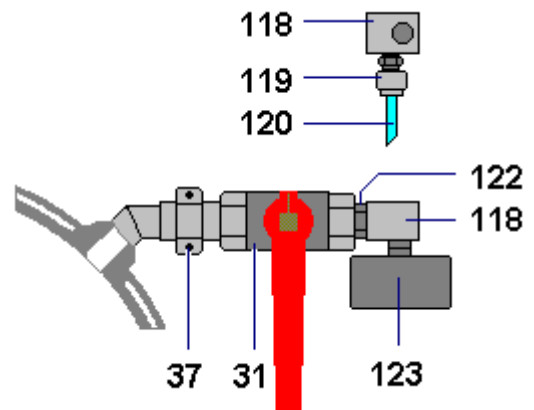

Sight glass / Flange

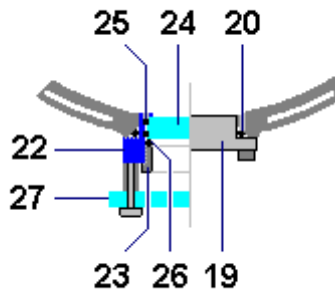

Safety

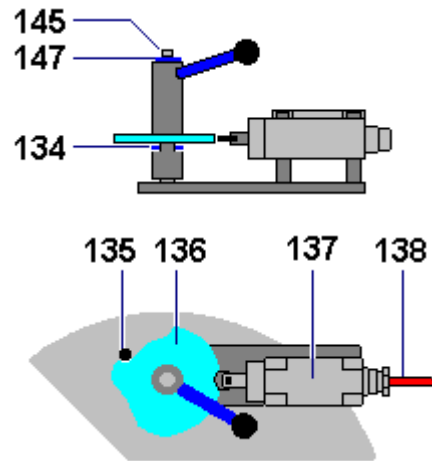

Outlet valve

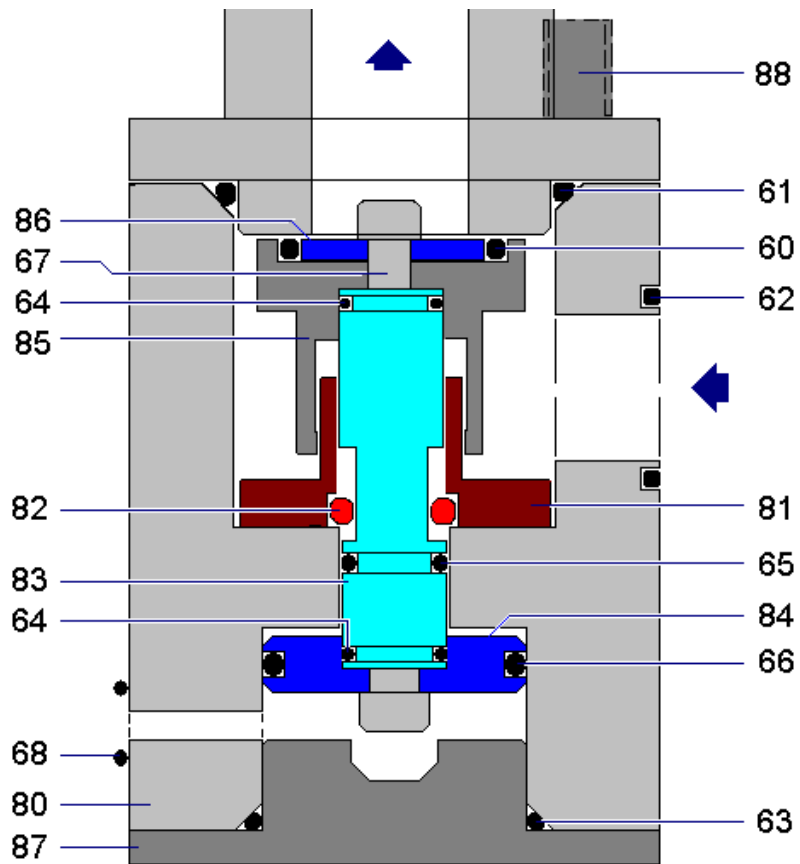

A.6.2 Parts / Diagram of KSEP 310

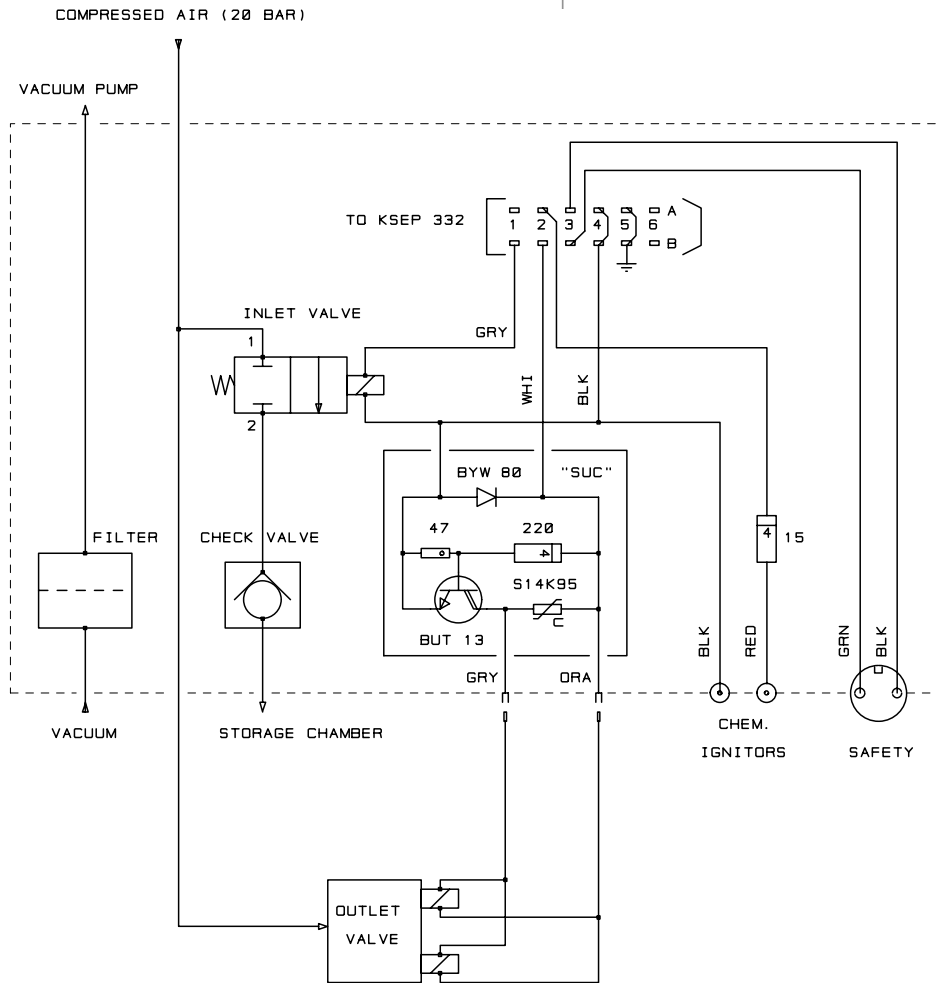
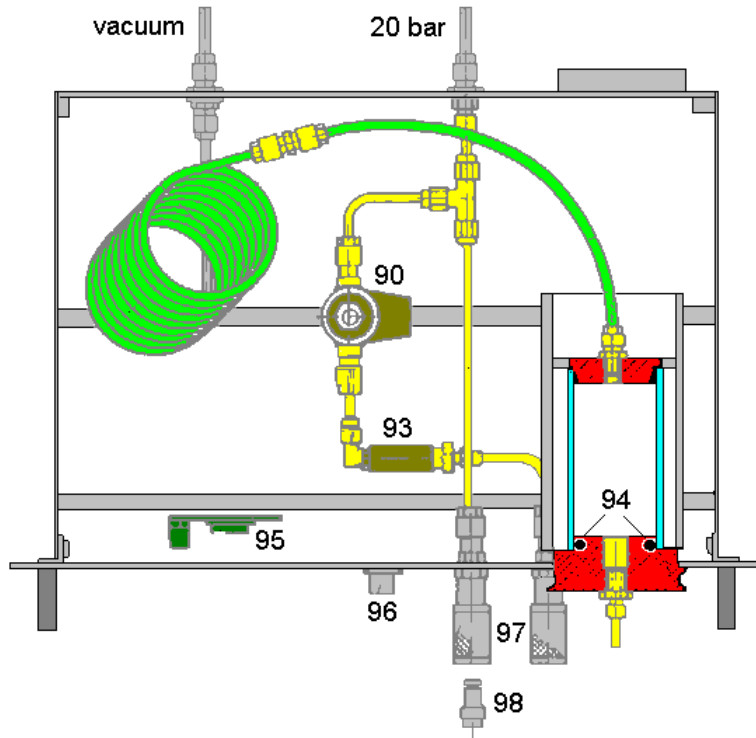

A.6.3 Spare Parts SP8xxx (number „xxx“ on drawings)

SP8000	Recommended set of spare parts	SP8050.2	Reducer with seal R 3/4" - 1/4"
SP8001	Electrode assembly	SP8050.3	Seal 26.5 x 33
SP8002	Rod	SP8051	O-ring 66.27 x 3.53 - 231
SP8003	Contact	SP8052	O-ring 88.27 x 5.33 -341
SP8004	Clamping screw	SP8053	Pressure line 1/4" - 1/4" 450 mm
SP8005	Insulator	SP8054	O-ring 26.64 x 2.62 - 121
SP8006	O-ring 14.00 x 1.78 - 015	SP8055	Dust storage chamber assembly
SP8007	Electrode tips (package of 100pcs)	SP8056	Cover for dust storage chamber
SP8008	Plug	SP8057	Glanged nipple
SP8009	Pressure seal	SP8058	Elbow fitting
SP8010	Ignition lead for chem. igniters	SP8059	Connector-half G 3/4"
SP8011	Ignition lead for high voltage (pair)	SP8060	O-ring 28.17 x 3.53 - 216
SP8012	O-ring 101.19 x 3.53 - 242	SP8061	O-ring 47.22 x 3.53 - 225
SP8013	O-ring 158.12 x 5.33 - 363	SP8062	O-ring 30 x 2
SP8014	O-ring 40 x 3	SP8063	O-ring 40 x 3
SP8015	Measuring flange assembly	SP8064	O-ring 11 x 2.5
SP8016	Measuring flange	SP8065	Quad ring 4111 - 366Y
SP8017	Sealing screw for flange	SP8066	Quad ring 4219 - 366Y
SP8018	O-ring 15.54 x 2,62 - 114	SP8067	Hex socket screw M6 x 16
SP8019	Solid flange	SP8068	O-ring 10.82 x 1.78 - 013
SP8020	O-ring 55.25 x 2.62 139	SP8069.1	Outlet valve assembly
SP8021	Sight glass assembly	SP8070	Solenoid valve type 123
SP8022	Sight glass support	SP8071	Solenoid valve type 122
SP8023	Threaded bushing	SP8072	Washer
SP8024	Sight glass 34.00	SP8073	Hex nut M10
SP8025	O-ring 44.12 x 2.62 - 132	SP8074	Hex socket screw M6 x 53
SP8026	Seal	SP8075	Hex socket screw M6 x 48
SP8027	Protective plate assembly	SP8076	Adjustable fitting
SP8031	Ball valve (vent / vacuum)	SP8077	Elbow fitting
SP8031.1	Repair seal set for ball valve	SP8090	Inlet valve
SP8032	Ball valve (water jacket)	SP8093	Check valve 1/8"
SP8033	Ring nozzle assembly	SP8094	O-ring 44.04 x 3.53 - 224
SP8035	Positioning unit for pos. 8033	SP8095	Speed up circuit
SP8036	Pressure line 1/8" - 1/4" 190 mm	SP8096	Chassis socket for outlet valve
SP8037	O-ring 21.95 x 1.78 - 020	SP8097	Quick connector female
SP8038	Lower flange	SP8098	Quick connector male
SP8040	Filler block	SP8118	Manifold assembly
SP8041	Sealing ring	SP8123	Vacuum gauge
SP8042	Guide ring	SP8123.1	Vacuum gauge assembly
SP8044	Upper flange	SP8134	Slide plate
SP8045	O-ring 4.47 x 1.78 - 008	SP8137	Safety switch
SP8050	Gauge assembly (40 bar)	SP8148	Safety assembly
SP8050.1	Gauge with pressure transfer unit	SP8200	Rebound nozzle

A.7 Report - Mask

Aim and object of the mask is to enter repetitive text and to define all those fields in which variables (e.g. test results) should be entered automatically for the report.

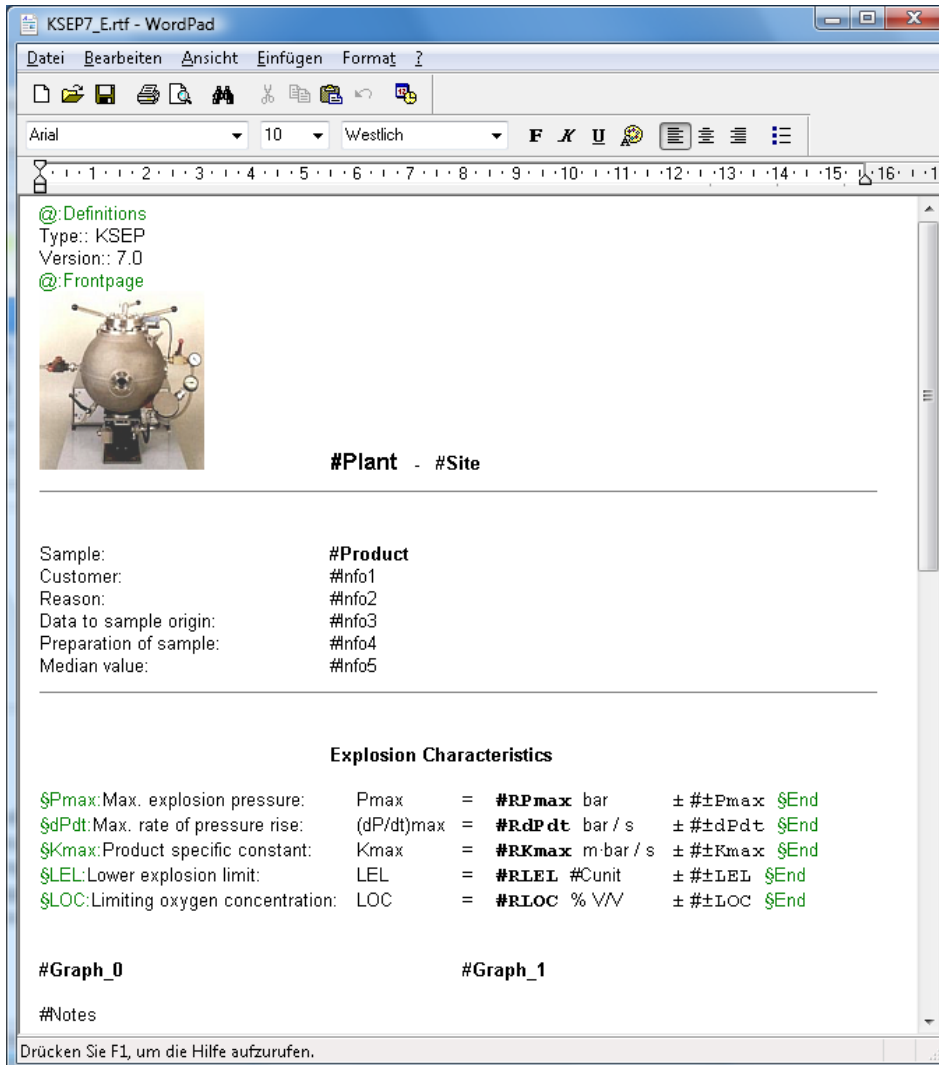

The KSEP-software contains sample masks in English and German. These masks can be easily adapted to your requirements. We recommend to use the Editor-program "**WordPad**" from Microsoft.

These masks are split into several sections. Each section starts with a "@:"-code. Please do never modify this codes. All fields for variables are marked by "#"-code.

While the use of fonts designed for proportional character spacing is possible, formatting of the results table will be difficult. Therefore we recommend to use fonts with fixed character spacing (e.g. Courier New) for tables.